

PRODUCT IMAGES

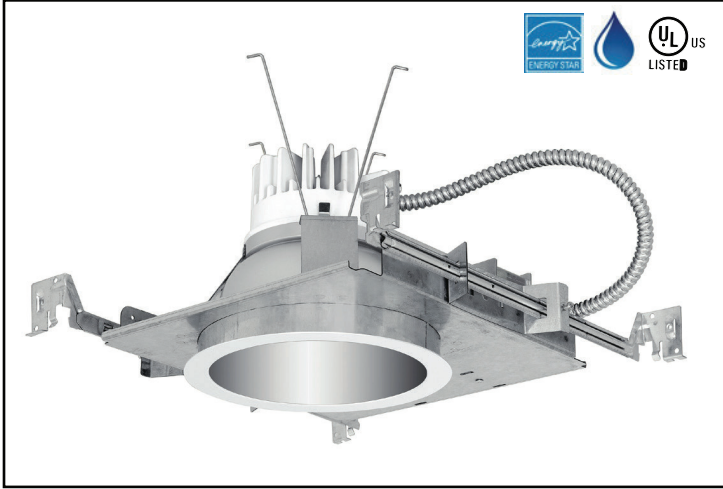

Standard Dimensions:

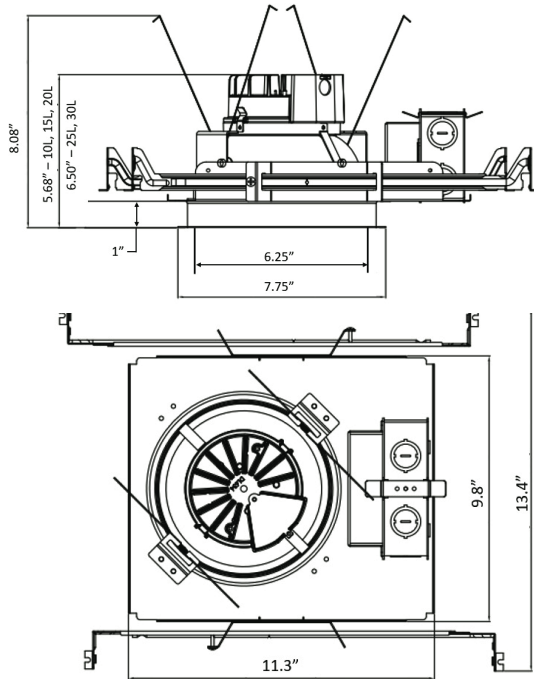

SPECIFICATIONS

Applications:

- New Construction Recessed Downlight suitable for Commercial and Architectural Applications.
- Suitable for ambient temperatures up to 35C (95F) with free airflow around fixture.

Key Dimensions

- Aperture – 6.25"
- Ceiling Cutout – 7.1"
- Overlap Flange – 7.75"

Construction:

- Galvanized Steel New Construction Housing
- Telescoping Bar Hangers Included (up to 24" grid)
- Light Engine and Driver Can Extend below the ceiling for ease of accessibility

Optical System:

- Self Flanged Aluminum Reflector with Semi-Diffuse Anodized Finish
- 45 degree visual cutoff to source
- 80+ CRI / 3 SDCM Color Consistency
- 70% Lumen Maintenance at 50,000+ Hours
- 80 to 100 Lumens Per Watt
- Lensed Wall Wash Option Available, may be orientated in 90 degree increments to housing
- Antimicrobial paint option eliminates 99.9% of E. Coli and Staphylococcus within 24 hours

Electrical:

- 120 thru 277v 50/60hz Input Power
- <20% THD; PF > 0.9
- EMI FCC 47CFR Part 15, Class A
- Standard 0-10v dimming to 10%, 1% dimming available,
- Driver Sources up to 2ma of current to the dimming circuit
- FCC Part15, Class A

Certifications:

UL listed for:

- Wet Location under covered ceilings with Downlight Option
- Damp Location under covered ceiling with Wall Wash Option
- Energy Star Listed

Battery Back Up

- EMR option supplied with a pre-wired 7watt LED battery that is UL Listed for Field Installation. Remote Test Switch included.
- EMI option supplied with a pre-wired 6watt LED self-diagnostic battery that is UL Listed for Field Installation. Test Switch ships with and is integral to the reflector. Not suitable for use with Wall Wash or NCT options.

Warranty:

- Standard 5 Year Limited Warranty
- See www.heliosltg.com/warranty for Details.

See Page 3 for additional dimensioned Line Art

ORDERING INFORMATION

ORDERING EXAMPLE: 6R15L35KAN

Aperture	Output	Kelvin	Reflector	Function	Dimming	Emergency
6R - 6" Round	05L - 500 lumens	30/20DTW - 3000K to 2000K Dim To Warm	AN - Semi-Diffuse Anodized Cone and Flange	Blank - Downlight	Blank - 10%, 0-10V	Blank - No Battery
	10L - 1000 lumens		WF - Anodized Cone and White Flange	WW- Lens Wall Wash	EMR - Battery Back Up with Remote Test Switch	
	15L - 1500 lumens		WH - White Cone & Trim	NCT - Non-Conductive Trim	DM1 - 1%, 0-10V	EMI - Battery Back Up with Integral Test Switch
	20L - 2000 lumens		BF - Anodized Cone & Black Flange			GTD - Generator Transfer Device, 0-10v compatible
	25L - 2500 lumens		BL - Black Cone and Black Flange			
	30L - 3000 lumens		AMB - Nano Antimicrobial White Paint			
	45L - 4500 lumens					
60L - 6000 lumens						

Housing and Reflector Ship Separately

Due to our continued efforts to improve our products, product specifications are subject to change without notice.

Alternate Housing Dimensions

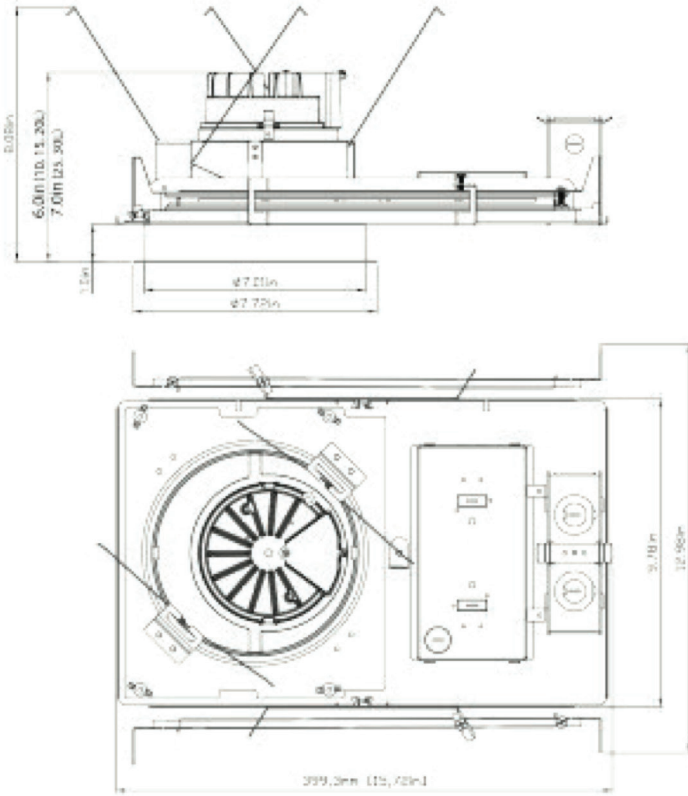

EMR and EMI Dimensions

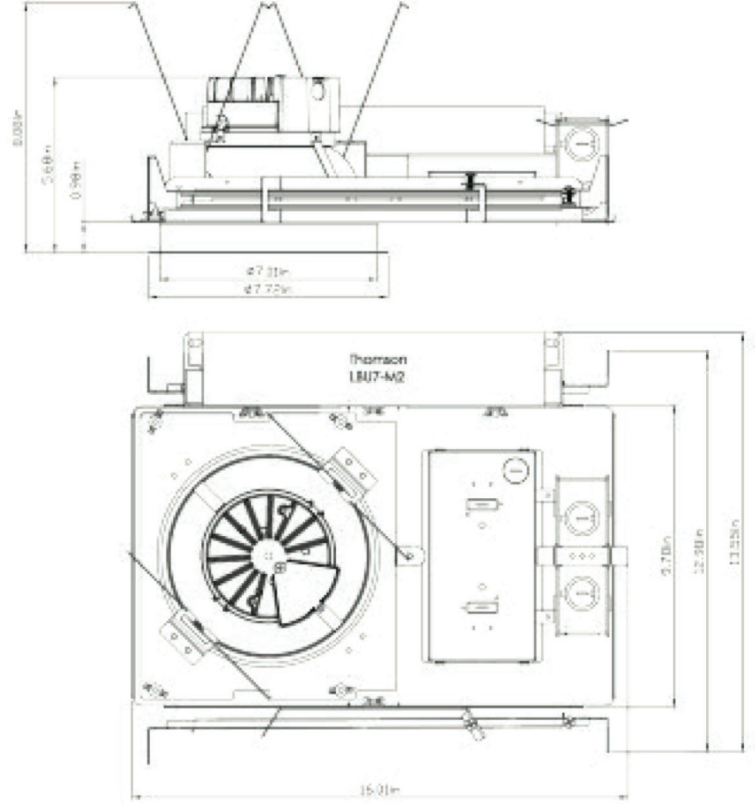

Housing and Reflector Ship Separately

Due to our continued efforts to improve our products, product specifications are subject to change without notice.

© 2019 Helios Lighting • All Rights Reserved • For more information visit our website: www.heliosltg.com

Revision: 08/17/23