

### PRODUCT IMAGES

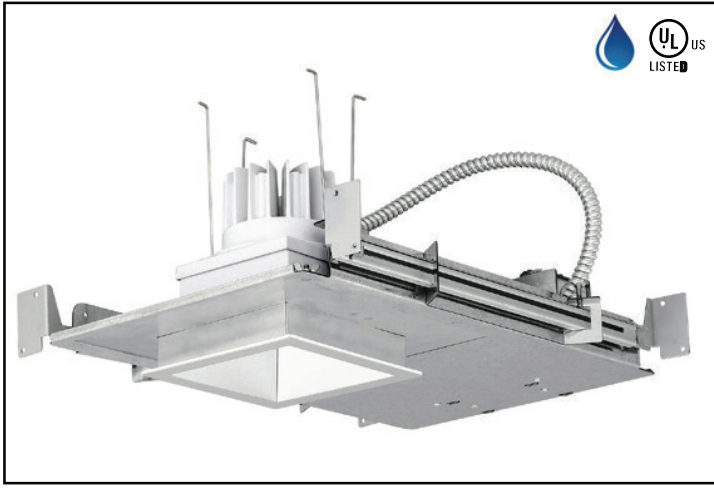

### Standard Dimensions:

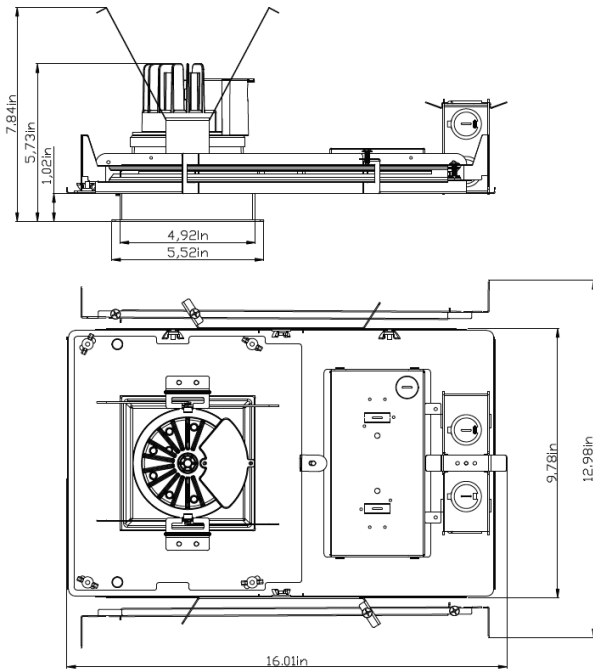

### SPECIFICATIONS

#### Applications:

- New Construction Recessed Downlight suitable for Commercial and Architectural Applications.
- Suitable for ambient temperatures up to 35C (95F) with free airflow around fixture.

#### Key Dimensions

- Aperture – 4.375"
- Ceiling Cutout – 4.875"
- Overlap Flange – 5.50"

#### Construction:

- Galvanized Steel New Construction Housing
- Telescoping Bar Hangers Included (up to 24" grid)
- Light Engine and Driver Can Extend below the ceiling for ease of accessibility
- Adjust of up to 7 degrees (each direction) rotationally for proper square alignment

#### Optical System:

- Self Flanged Aluminum Reflector with Semi-Diffuse Anodized Finish
- 90+ CRI Option
- Dim To Warm Option from 3000K to 2000K
- 70% Lumen Maintenance at 50,000+ Hours
- Lensed Wall Wash Option Available, may be orientated in 90 degree increments to housing

#### Electrical:

- 120 thru 277v 50/60hz Input Power
- <20% THD; PF > 0.9
- EMI FCC 47CFR Part 15, Class A
- Standard 0-10v dimming to 10%, 1% dimming available,
- Driver Sources up to 2ma of current to the dimming circuit
- FCC Part15, Class A

#### Certifications:

UL listed for Non-IC applications:

- Wet Location under covered ceilings with Downlight Option

#### Battery Back Up

- EMR option supplied with a pre-wired 7watt LED battery that is UL Listed for Field Installation. Remote Test Switch included.
- With EMI option, battery is accessible from below the ceiling. Top access required for EMR option.
- EMI Option supplied with a pre-wired 6watt, self-diagnostic, LED battery that is UL Listed for field installation. Test switch is supplied pre-installed integral with the reflector. Not suitable for use with Wall Wash reflector.

#### Warranty:

- Standard 5 Year Limited Warranty
- See [www.heliosltg.com/warranty](http://www.heliosltg.com/warranty) for Details.

### ORDERING INFORMATION

ORDERING EXAMPLE: 4S15L35K9AN

Aperture	Output	Kelvin	Reflector	Function	Dimming	Emergency
4S - 4" Square	10L - 1000 lumens	30K9 - 90+ CRI	AN - Semi-Diffuse Anodized Cone and Flange	Blank - 70° Wide Beam Downlight	Blank - 10%, 0-10V DM1- 1%, 0-10V	Blank - No Battery
	15L - 1500 lumens	35K9 - 90+ CRI	WF - Anodized Cone and White Flange	MED - 50° Medium Beam Downlight		EMR - Battery Back Up with Remote Test Switch
	20L - 2000 lumens	40K9 - 90+ CRI	WH - White Cone & Trim	NRW - 25° Narrow Beam Downlight		EMI - Battery Back Up with Integral Test Switch
	25L - 2500 lumens	30/20DTW - 3000K to 2000K Dim To Warm	BF - Anodized Cone & Black Flange BL - Black Cone and Black Flange	SPT - 15° Spot Beam Downlight WW - Lens Wall Wash (not available with 2500 lumen)		GTD - Generator Transfer Device, 0-10v compatible

Housing and Reflector Ship Separately

Due to our continued efforts to improve our products, product specifications are subject to change without notice.